

Creative Light 1 (CL1) Creative Light 1 Plus (CL1+)

User Manual



Revision 20210303-01



Document revisions

Revision number	Notes	Date released
20210303-01	First version available Firmware v. 1.2.0	March 3, 2021

GLP® Creative Light 1 (CL1) and Creative Light 1+ (CL1+) User Manual

© 2020-2021 German Light Products GmbH. All rights reserved.

The marks 'GLP' and 'German Light Products' are trademarks registered as the property of German Light Products GmbH in Germany, in the United States of America and in other countries.

The information contained in this document is subject to change without notice. German Light Products GmbH and all affiliated companies disclaim liability for any injury, damage, direct or indirect loss, consequential or economic loss or any other loss occasioned by the use of, inability to use or reliance on the information contained in this document.

Head office:

German Light Products GmbH (GLP), Industriestrasse 2, 76307 Karlsbad, Germany
Tel (Germany): +49 7248 92719 - 0

Service & Support EMEA:

GLP, Industriestrasse 2, 76307 Karlsbad, Germany

Tel. (Germany): +49 7248 9271955

Email: support@glp.de

www.glp.de

Service & Support USA:

GLP USA, 1145 Arroyo St., Ste. A, 91340 San Fernando, California

Tel (USA): +1 818 767 8899

Support (US): info@germanlightproducts.com

www.glp.de

Table of Contents

1. Safety	5
General safety information	5
Electrical safety	6
Installation safety and protection from personal injury	6
Battery safety.....	7
2. Features	8
3. Product overview.....	9
4. Control panel and display	10
Control panel display	10
Control panel functions.....	12
Accessing the control menus	13
5. Preparing for use.....	14
Charging	14
Transport lock	15
Powering on and off	15
6. Configuring the CL1	16
Default control settings.....	16
Control options.....	16
Fixture Settings	17
Manual Control menu	18
Fixture and iQ.Mesh information	18
Service	18
Loading factory backup	18
Linking to a CRMX Transmitter (CL1+ only)	19
DMX settings (CL1+ only)	19
Setting up iQ.Mesh control.....	19
7. Manual control.....	20
8. Infrared remote control.....	21
Pattern color	22
Pattern Effects	22
Effect Speed	22
Global Intensity / Blackout	22
Automatic Colors	23
Color changing type	23
Light output On/Off	23

9. Creative Light app control	24
Setting up the iQ.Mesh network	24
Using the Creative Light app	26
10. DMX control (CL1+ only)	28
Global intensity	28
Global Shutter / Pattern Shutter	28
Virtual color wheel	29
RGB / Pattern RGB.....	29
Control / Settings.....	29
Pattern Control (available in Pattern DMX Mode)	30
11. Mounting and installing	31
Temporary installation	31
Fixed installation	31
Adding optical accessories	31
Securing with a safety cable	32
Mounting on a UFO1 (Universal Fixing Object 1)	32
Using an external power source	32
12. Cleaning and product care	33
Suggested cleaning intervals	33
Checking firmware version	33
Uploading new firmware.....	33
Battery care	35
Caring for the environment	35
GLP Service and Support	35
13. Control menus	36
14. DMX control modes overview (CL1+ only)	39
15. DMX channel index (CL1+ only)	41
DMX Mode 1: Basic	41
DMX Mode 2: Pattern (default mode).....	43
DMX Mode 3: MultiPix	49
16. Technical Data	50
17. Dimensions	52

1. Safety

Key to symbols

The following symbols are used in this manual:



Warning!
Safety hazard.



Warning!
Risk of electric shock.



Warning!
See user documentation
for important safety
information.



General safety information

Read this section carefully before installing the product. If you have any questions about the product, contact your GLP® supplier for assistance. Your GLP supplier will be happy to help.

- Respect all warnings and directions given in this manual and on the product. Read this manual and familiarize yourself with the safety precautions it contains before installing or using the product. The manufacturer will take no responsibility for damages or harm resulting from disregard for the information in this manual.
- Check the GLP website at www.glp.de and make sure that you have the latest version of this quick start guide.
- Make this manual available to any person who is responsible for installing, operating or servicing the product.
- Use the product only as directed in this manual. Observe all markings in this manual and on the product.
- Do not modify the product in any way not described in this manual.
- The LEDs that form the light source in this product are not replaceable.
- Ensure that there is free and unobstructed airflow around the product.
- Do not attempt to open the product. There are no user-serviceable parts inside. Opening the product can create a safety risk and will void the product warranty. If the product becomes defective, contact your GLP supplier for assistance. Do not try to carry out repairs yourself.



Electrical safety

- The product is for indoor use in dry locations only. Do not allow the product to become wet.
- Disconnect the product from its charger before cleaning. Clean the product with a soft, dry cloth only. Do not clean with solvents or abrasive products.
- Ensure that any equipment used to charge the product is electrically connected to ground (earth).
- Disconnect equipment used to charge the product from power if the charging equipment, power plug, power cable, any cover or any other component is damaged, defective or deformed. Do not reapply power until the product has been repaired and made safe by a technician authorized by GLP.



Installation safety and protection from personal injury

- Do not stare directly into the light output at close range. Looking into the light output at close range may cause eye injury or irritation.
- Install the product in a dry, dust-free location where it will not be exposed to high temperatures or direct sunlight.
- Ensure that the product is safely supported and cannot fall. If mounting the product on a wall or other vertical surface or structure, use fasteners that are suitable for the surface and strong enough to safely hold the weight of the product.
- The product's integrated magnet may be used for temporary installation on magnetic surfaces.
- In permanent installations, fasten the product to a surface or structure with screws fastened into the threaded holes provided on the product or secure the product against falling by adding an approved safety attachment as directed in this manual.
- Fasten the product to a structure or surface only as directed in this manual.
- If there is any risk that the product may cause injury or damage if it falls, secure it with an approved secondary attachment as described in this manual.
- The product can become hot during normal operation. Take precautions to prevent accidental physical contact with the product. Allow to cool before handling.

- Do not illuminate surfaces and objects that are less than 0.3 m (0.98 ft) from the product.
- Keep the product away from flammable or volatile materials.



Battery safety

- This product contains a rechargeable single-cell 3.7volt lithium-ion battery with a capacity of 10 000 mAh.
- Respect all applicable laws and regulations for the transport, storage and disposal of batteries.
- Do not expose the battery to fire or heat.
- Protect the battery and product from physical shocks.
- Do not allow the battery to come into contact with water.
- Do not short-circuit a lithium-ion battery, or you may cause a battery explosion.
- Charge the battery at an ambient temperature of between 15° C (59° F) and 35° C (95° F).
- Do not charge the battery in an enclosed space. Leave the product's container, tourpack case or flightcase open during charging.
- Do not connect a battery charger to a product that may be damaged or faulty.
- If the battery becomes faulty or will not hold a charge, replace it with an original spare part from GLP only.
- The battery must be serviced by authorized personnel only.

2. Features

The GLP Creative Light 1 (CL1) is a wireless, battery-powered visual effect fixture for the semi-professional event and professional entertainment market. Each CL1 has 24 individually controllable RGB pixels. Two different optical front screens are supplied with the CL1, as well as a USB-A to USB-C charging cable. You can charge the CL1 using any standard USB charger. A traveling multi-device case with integrated charging system is available as an optional accessory.

The CL1 is a highly advanced fixture in a compact package. It creates stunning light effects using the integrated dynamic FX engine or when driven by individual RGB pixel control. The fixture is perfect for setting creative visual highlights, illuminating walls or integrating into dark areas of sets. The CL1 lets you create impressive visual effects with minimal equipment size and budget.

Depending on the selected performance mode, the integrated battery can power visual effects for up to 10 hours with white output and 24 hours with single-color output.

The Creative Light 1 comes in two versions:

- The **Creative Light 1 (CL1)** can be controlled by IR Remote Control, by mobile device via the GLP iQ.Mesh* system and GLP Creative Light app, and by use of the control panel on the front of the fixture.
- The **Creative Light 1 Plus (CL1+)** offers all of the features of the CL1 but in addition it features integrated LumenRadio CRMX TiMo technology that allows control by wireless DMX.

This manual uses the name CL1 to refer to both the CL1 and CL1+ unless stated otherwise.

If you have any questions about the CL1, the CL1+, CRMX, DMX control or iQ.Mesh, for example, please contact your GLP supplier who will be happy to help you.

** **iQ.Mesh** is a new wireless mesh network technology available from GLP. iQ.Mesh allows fixtures to communicate with each other, share data and receive and amplify signals to set up huge networks. The **GLP Creative Light** smartphone app allows communication with the mesh network and direct fixture control.*

When controlled via the app, CL1 fixtures can generate an iQ.Mesh wireless network with no need for any additional hardware. Each CL1 receives and amplifies the signal, allowing the network to cover long physical distances.

*The **GLP Creative Light** app provides an intuitive user interface and allows fast, easy system setup. Multiple devices can be grouped for live control of intensity, strobe and pulse effects, background and foreground colors, a variety of dynamic patterns and sound-to-light audio triggering. The app is available from Play Store for Android and App Store for iOS.*

3. Product overview

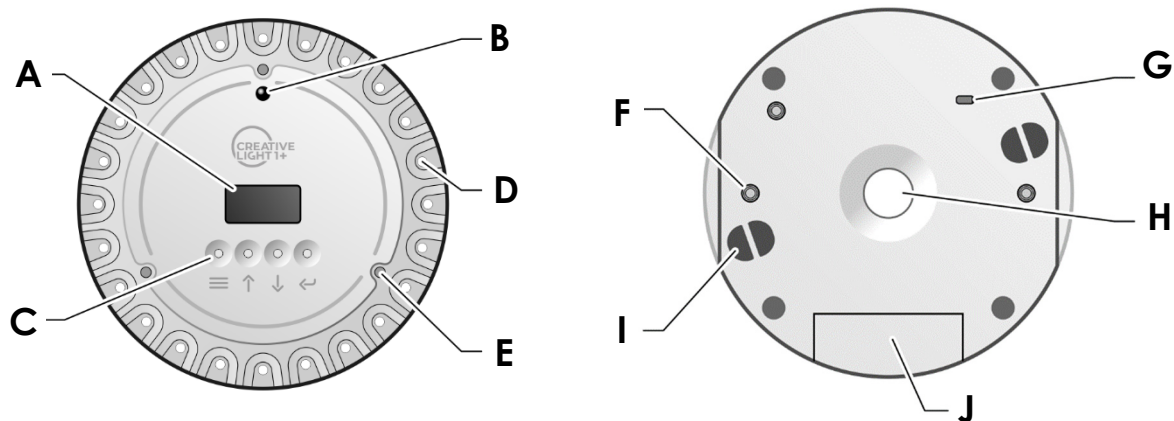

Figure 1. Product overview

- A** – Monochrome OLED display
- B** – Sensor for IR remote control
- C** – 4 x control buttons
- D** – 24 x individually controllable RGB LEDs
- E** – 3 x magnetic mounting points for optical accessories
- F** – 3 x M6 threaded holes for mounting fasteners and/or eyebolt for secondary attachment

- G** – Slot for Kensington security lock system
- H** – Mounting magnet embedded in non-slip rubber
- I** – 2 x attachment points for secondary attachment
- J** – USB-C connector for charging, continuous power and service, two charging ports

4. Control panel and display

The control panel on the front of the CL1 consists of an integrated monochrome OLED display and four control buttons.

Control panel display



The CL1's OLED display shows the following information:

P01/S04/X04

Main status display

- If the CL1 or CL1+ is in Manual Mode:
Shows the selected Pattern, Speed and Crossfading settings. For example: **P01/S04/X04** indicates Pattern 01, Pattern Speed 04 and XFade setting 04.
- If the CL1 or CL1+ is in iQ.Mesh mode:
Shows iQ.Mesh status.
- If the CL1+ is in DMX Mode:
Shows the DMX Mode and the DMX Start Address. For example, **DMX-M2-302** indicates DMX Mode, Control Mode 2 and DMX Start Address 302.



Charge status

- Remaining battery charge.
- Plug icon shows that the device is connected to power.
- Increasing sectors in the battery icon indicate that the device is charging.



Audio triggering

- Internal audio triggering microphone enabled / disabled.
- Audio triggering microphone sensitivity 1 (lowest) to 10 (highest).



Software

- Currently installed firmware version.

N

Power mode

- **N** – Normal. Output is balanced for long performance with optimized output. Performance time depends on intensity level and color. Continuous performance without battery charges requires an external power supply of minimum 2 amps.
 - **H** – High Power. Output is optimized for highest brightness. Performance time depends on intensity level and color. Continuous performance without battery charges requires an external power supply of minimum 3 amps.
 - **E** – Eco. Output is optimized for longest performance time between battery charges. Performance time depends on intensity level and color. Continuous performance without battery charges requires an external power supply of minimum 2 amps.
-

Show

Signal status

- **Show** – Fixture is in Manual Mode. The standalone pattern can be selected using the IR remote control or the integrated control buttons.
 - **No Signal** (CL1+ only) – Fixture is in DMX Mode but is not receiving DMX data via CRMX. The fixture is following the settings that are currently active in the NO-SIGNAL BEHAVIOR menu.
 - **DMX** (CL1+ only) – Fixture is in DMX Mode and is receiving DMX data via CRMX.
-

IR (ON)

Signal source

- **IR (ON)** – Manual Mode is selected and IR remote control is enabled. You can control the fixture using the integrated control buttons (MANUAL CONTROL menu) or the IR remote control.
- **IR (OFF)** – Manual Mode is selected and IR remote control is disabled. You can control the fixture using the integrated control buttons (MANUAL CONTROL menu).
- **CRMX** (CL1+ only) – LumenRadio CRMX module is enabled and the CL1+ is ready to be controlled via DMX. The status of CRMX communication is indicated as follows:

CRMX ---

Horizontal dashes – the CRMX module is not linked to a CRMX transmitter.

CRMX ||||

Vertical bars – the CRMX module is linked to a CRMX transmitter. The bars indicate signal quality.

Control panel functions

The CL1's four control buttons have the following functions:



MENU button

- Press and hold for 3 seconds: switch CL1 on and off.
- Press once briefly: open the control menus for manual control or configuration.
- If you are in one of the control menus, press once briefly to exit the current menu without making any changes.
- If the top-level control menu is active, press and hold for 20 seconds to carry out a hard reset. This will disconnect the battery from the controller for a few seconds while it fully restarts the CL1.



UP and DOWN buttons

- Scroll up and down through menus.
- If the display is activated and you see the main screen, press and hold the DOWN button for 3 seconds to change the signal source



ENTER button

- If you are in the control menus, confirm a selection or save a change.
- If the top-level control menu is active, press and hold for 6 seconds to re-initialize the CL1 and return it to its original factory settings. All custom settings and control configuration settings will be deleted.
NB: Re-initializing will return the DMX address to 001 and unlink the CL1 from any existing CRMX or iQ.Mesh link, so you may lose the connection to your controller.



MENU and ENTER buttons together

- If the top-level control menu is active, pressing and holding the MENU button and the ENTER button together for 6 seconds applies the transport lock and disables all the control buttons. We recommend that you apply the transport lock to avoid accidentally powering the CL1 on during transport or long-term storage.

To unlock the CL1, connect it to a charger.

Accessing the control menus

To enter the CLI's control menus:

1. See Figure 2. Press the MENU or ENTER control button once to activate the display.
2. Press the MENU button to enter the menu structure.

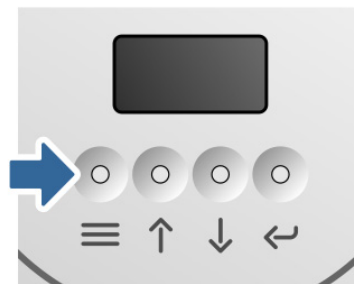

Figure 2. Menu button

5. Preparing for use



Warning! Read 'Safety' starting on page 5 for important safety information that you must understand before you charge, install or operate the fixture. Follow the warnings and instructions in the user documentation of all involved products during charging.

Important! Connect the CL1 to a USB power source and charge it to 100% before using it for the first time. To avoid draining the battery unnecessarily, power the CL1 off when not in use and apply the transport lock before long-term storage or transport.

Charging

Charge the CL1 to 100% before using it for the first time.

When using the GLP Creative Light app, you can see the CL1's current battery charge level on your smartphone.

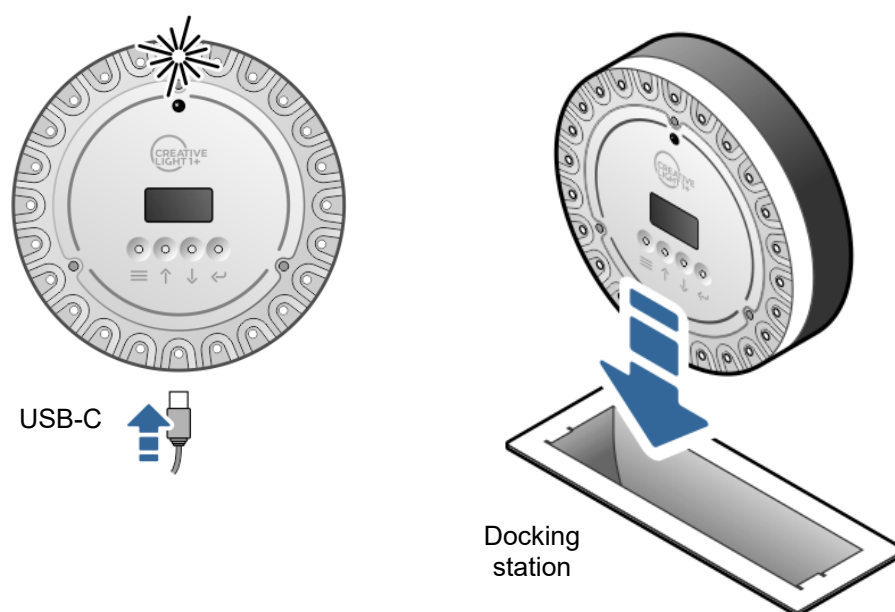

Figure 3. Charging options

See Figure 3. After unboxing the CL1 and before you switch it on, connect it to a source of USB power using the supplied USB-A-to-USB-C cable in order to charge it. The power source can be a laptop, USB charger or powerbank, for example, that can supply minimum 1 amp.

A 1 amp power supply is suitable for charging only: the CL1 must be powered off during charging. When operating the CL1 continuously under external power, the CL1 requires a current of minimum 2 amps in **Normal** and **Eco** power modes and 3 amps in **High** power mode. The CL1 is designed for use with normal and fast charging, but using USB superfast charging together with a USB-C to USB-C cable may result in the battery not being fully charged.

You can also charge multiple CL1 devices using the docking stations in the Creative Light 1 charging tourpack case that is available as an optional accessory from GLP suppliers. Leave the case open during charging.

See Figure 4. You can monitor the charging process as follows:

- During charging, the first LED pixel flashes green (A) and the CL1's display shows a charging symbol.
- When the CL1 is fully charged, the first LED pixel lights constant green (B) for as long as the CL1 is connected to the charger.
- When you disconnect the CL1 from the charger, the first LED pixel switches off (C).

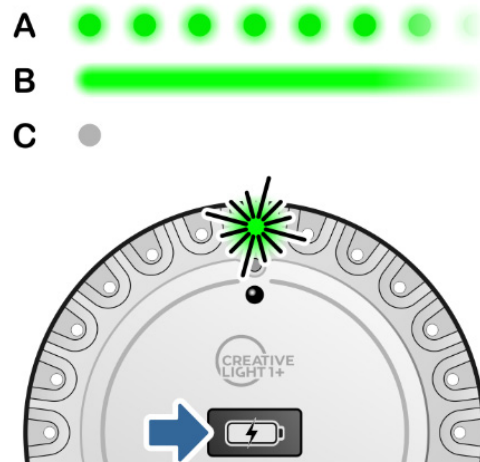

Figure 4. Charging status

Transport lock

The CL1 ships with the transport lock applied. To unlock the CL1 when the transport lock is applied, connect it to a charger.

If you are going to transport the CL1 or put it into long-term storage, apply the transport lock. This disables all control buttons. To unlock the CL1 when the transport lock is applied, connect it to a charger.

Powering on and off

See Figure 5. To switch on the CL1, press and hold the MENU button for 3 seconds. The CL1's LEDs will light up white in a circle show you that the fixture is starting up. The CL1 is now ready to use and you can start configuration.

To switch off the CL1 while it is powered on, press and hold the MENU button for 3 seconds. The CL1's LEDs will light white and then turn off in a counterclockwise circle to show you that the CL1 is shutting down. You can now store the CL1 without draining the battery.

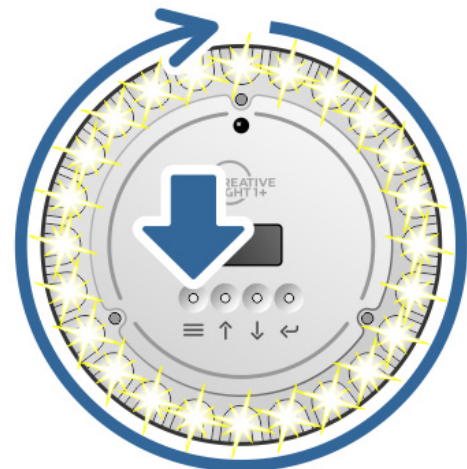

Figure 5. Powering on

6. Configuring the CL1

The menus in the control panel on the front of the CL1 give a range of options for configuring the fixture. See 'Control menus' on page 36 for an overview of the menus.

In the CL1+, a range of configuration options is also available via DMX on the Control / Settings DMX channel. See the DMX Channel Index section at the back of this manual for details.

The configuration options available are described in this chapter.

Default control settings

By default, the CL1 and CL1+ are set up as follows:

- The CL1 is set to SIGNAL SOURCE: iQ.Mesh and NO-SIGNAL: MANUAL CONTROL. This means the fixture automatically switches to manual / IR remote control as long no valid iQ.Mesh Signal is being received or the fixture is not linked to the Creative Light smartphone app.
- The CL1+ is set to SIGNAL SOURCE: CRMX and NO-SIGNAL: MANUAL CONTROL. This means the fixture automatically switches to manual / IR remote control as long no valid CRMX Signal is being received or the fixture is not linked to CRMX.

You can change these default settings in the fixture's control menus under SIGNAL SETTINGS → SIGNAL SOURCE and FIXTURE SETTINGS → NO-SIGNAL BEHAVIOR. See the following sections for details.

Control options

To select a control method for the CL1:

1. Enter the control menus and use the UP and DOWN buttons to scroll to SIGNAL SETTINGS. Press ENTER.
2. Scroll to SIGNAL SOURCE. Press ENTER.
3. Scroll to one of the following options and press ENTER to select:

- **CRMX** (CL1+ only)

If you select CRMX, the letters **CRMX** appear in the bottom right-hand corner of the CL1+ display. You can now link the fixture to a CRMX transmitter. See 'Linking to a CRMX Transmitter (CL1+ only)' on page 19 for instructions. Once the fixture is linked you can control the CL1+ by DMX.

Note: Don't forget to choose a DMX Control Mode in the CONTROL MODE menu and give the CL1+ a suitable DMX Address in the DMX ADDRESS menu.

- **iQ.Mesh**

If you select IQ.MESH, the name **iQ.Mesh** appears in the bottom right-hand corner of the CL1 display. You can now link the CL1 to GLP's iQ.Mesh network and Creative Light smartphone app. See 'Creative Light app control' on page 24 for instructions.

- **Manual / IR Remote**

If you select MANUAL / IR REMOTE, IR appears in the bottom right-hand corner of the CL1 display followed by ON or OFF depending on whether IR remote control is enabled or disabled in the separate SIGNAL SETTINGS → IR REMOTE CONTROL ON/OFF menu. You can now control the CL1 using the MANUAL CONTROL menu or using the infrared remote control that is supplied with the CL1. See 'Manual control' on page 20 and 'Infrared remote control' on page 21 for details of control options.

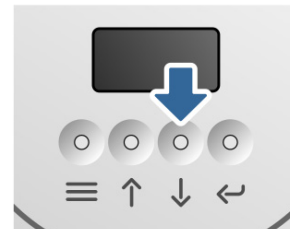

Figure 6. DOWN button

Tip! See Figure 6. As a shortcut, you can switch between control signal sources by pressing and holding the DOWN button for 3 seconds.

Fixture Settings

- **No-signal Behavior** lets you decide what the fixture should do if it is powered on but not receiving (or has not received) a control signal. You can set the CL1 to either black out, continue using the last commands it received via CRMX or iQ.Mesh, or switch over to manual control.
- **Mic Sensitivity** adjusts the sensitivity of the CL1's built-in microphone. The microphone is used for audio triggering, which gives you various options for synchronizing lighting changes with a music beat, for example.

If you set the CL1 to audio triggering and it does not respond to music, increase microphone sensitivity towards 10 (the highest sensitivity setting). If the CL1 responds too actively to music, reduce microphone sensitivity towards 1 (the lowest setting) until you obtain optimum performance.

- **Power Mode** lets you choose how you prioritize light output versus length of operating time on one battery charge. There is a trade-off between these two parameters, of course. Power Mode lets you choose maximum light output, maximum operating time between battery charges or a good compromise between these two settings.
- **Emergency Light** lets you define a static scene that the CL1 will display if it is connected to external power but then external power is disconnected. You can use Emergency Light as a control feature or as a way of providing emergency lighting in the event of a loss of power.
- **Default Settings** returns the CL1 to its factory default settings *without affecting* its control configuration. Mic Sensitivity, No-Signal Behavior etc. are returned to their factory default settings, but DMX Address, Signal Source and Control Mode are not changed. The CL1's default settings are printed in **bold type** in the control menus table starting on page 36.

Manual Control menu

The Manual Control menu lets you use the control panel on the front of the CL1 to display a static scene or run a dynamic pattern over the top of the main color. See full details under 'Manual control' on page 20.

Fixture and iQ.Mesh information

The **Information** menu lets you call up information about the CL1's fixture software (firmware) versions and operating data. It also lets you call up information about the iQ.Mesh system and see the fixture's current iQ.Mesh status.

Service

The **Service** menu gives three options for managing the CL1's firmware and settings.

- **iQ.Mesh Upload** prepares the CL1 for a firmware upload over an iQ.Mesh network using the GLP Creative Light smartphone app. See the section on 'Uploading new firmware' on page 33 for details.
- **Load Setting Defaults** is identical to the **Default Settings** command in the **Fixture Settings** menu. It returns the CL1 to its factory default settings *without affecting* its control configuration. Mic Sensitivity, No-Signal Behavior etc. are returned to their factory default settings, but DMX Address, Signal Source and Control Mode are not changed. The CL1's default settings are printed in **bold type** in the control menus table starting on page 36.
- **Load Factory Backup** re-initializes the CL1 completely. It returns the CL1 to its factory default settings *including* its factory-set control configuration. Mic Sensitivity, No-Signal Behavior etc. DMX Address, Signal Source and Control Mode are all returned to the original factory default settings. The CL1's default settings are printed in **bold type** in the control menus table starting on page 36.

Important! A Load Factory Backup command will reset the CL1 to **Manual / IR Remote** control. Any link to CRMX or iQ.Mesh control will be cut off.

Loading factory backup

To re-initialize the CL1 and restore its original factory settings, switch the fixture on, then use a shortcut by holding the ENTER button pressed in for 6 seconds. The CL1's individual configuration with all custom settings is returned to factory defaults.

Important! If you are using CRMX (CL1+ only) or iQ.Mesh control, note that loading factory backup returns the fixture to an unlinked state, breaking off communication with the CRMX link or iQ.Mesh network.

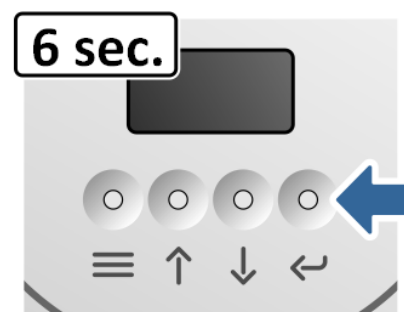

Figure 7. Restoring factory settings

In the CL1+, the DMX address also returns to the factory default, which is 001.

To re-establish CRMX control, see below.

To re-establish iQ.Mesh control, see 'Setting up iQ.Mesh control' on page 19.

Linking to a CRMX Transmitter (CL1+ only)

Whenever CRMX is enabled and the CL1+ is not already linked, it searches for a LumenRadio CRMX transmitter.

To link the CL1+ with a new CRMX transmitter:

1. Enter the control menus, navigate to SIGNAL SETTINGS → SIGNAL SOURCE and select CRMX.
2. Navigate to SIGNAL SETTINGS → CRMX LINK and select LINK/UNLINK.
3. Start the linking process at the CRMX transmitter as described in the transmitter's user manual.

TIP: The quickest way of setting up multiple CL1+ fixtures for DMX use is to carry out a LOAD FACTORY BACKUP on each fixture by pressing and holding its ENTER Button for 6 seconds. This will return the fixture to factory settings and delete all CRMX and iQ.Mesh links. The fixtures are now ready for linking to a transmitter. After successful linking, set up the fixtures' DMX addresses and DMX control mode.

DMX settings (CL1+ only)

When using DMX control via CRMX, you need to consider the following setup options.

DMX Address

If you want individual control of the CL1+ in an installation containing more than one fixture, you will need to give the CL1+ its own individual DMX address. Fixtures of the same type that share the same DMX address behave identically.

The CL1+ is set to DMX address 001 by default.

DMX Modes

The CL1 has three DMX control modes: Basic, Pattern and MultiPix modes. The different modes give you a choice of control options. See 'DMX control modes overview (CL1+ only)' starting on page 39 for details.

Setting up iQ.Mesh control

To set up a CL1 fixture so that you can control it with the GLP iQ.Mesh system and Creative Light smartphone app, open the control menus, navigate to SIGNAL SETTINGS → SIGNAL SOURCE and select iQ.Mesh. See full details under 'Creative Light app control' on page 24.

7. Manual control

If you set the CL1 to MANUAL / IR REMOTE CONTROL in the SIGNAL SETTINGS menu (you can also use a shortcut by pressing and holding the DOWN button to scroll through the control signal sources), you can control it manually using the CL1's integrated control panel.

Manual control gives the same options as Pattern DMX Mode (see 'DMX Mode 2: Pattern' on page 39). Additionally, you can set changes between steps in patterns to snap (instant change from one step to the next) or crossfade (fade from one step to the next).

The control options available when using Manual control are as follows:

- **Master Intensity** gives 0 – 100% continuous dimming of the complete fixture.
- **Main Color** lets you set the LED pixels to display a custom RGB color, one of 30 color presets or one of 4 color chaser options.
- **FX Layer** provides control of 40 patterns that can be superimposed over the main color with variable visibility and speed. You can control pattern intensity and color using RGB color mixing plus the color presets from the Color Wheel DMX channel.
- **Color Crossfade** lets you set steps in the pattern to snap or fade to the next.

8. Infrared remote control

If you set the CL1 to SIGNAL SOURCE → MANUAL / IR REMOTE CONTROL in the SIGNAL SETTINGS menu (you can also press and hold the DOWN button to scroll through the control signal sources), you can control it using the CL1's integrated display and control panel or the supplied IR remote control unit.

The remote control unit has the following features:

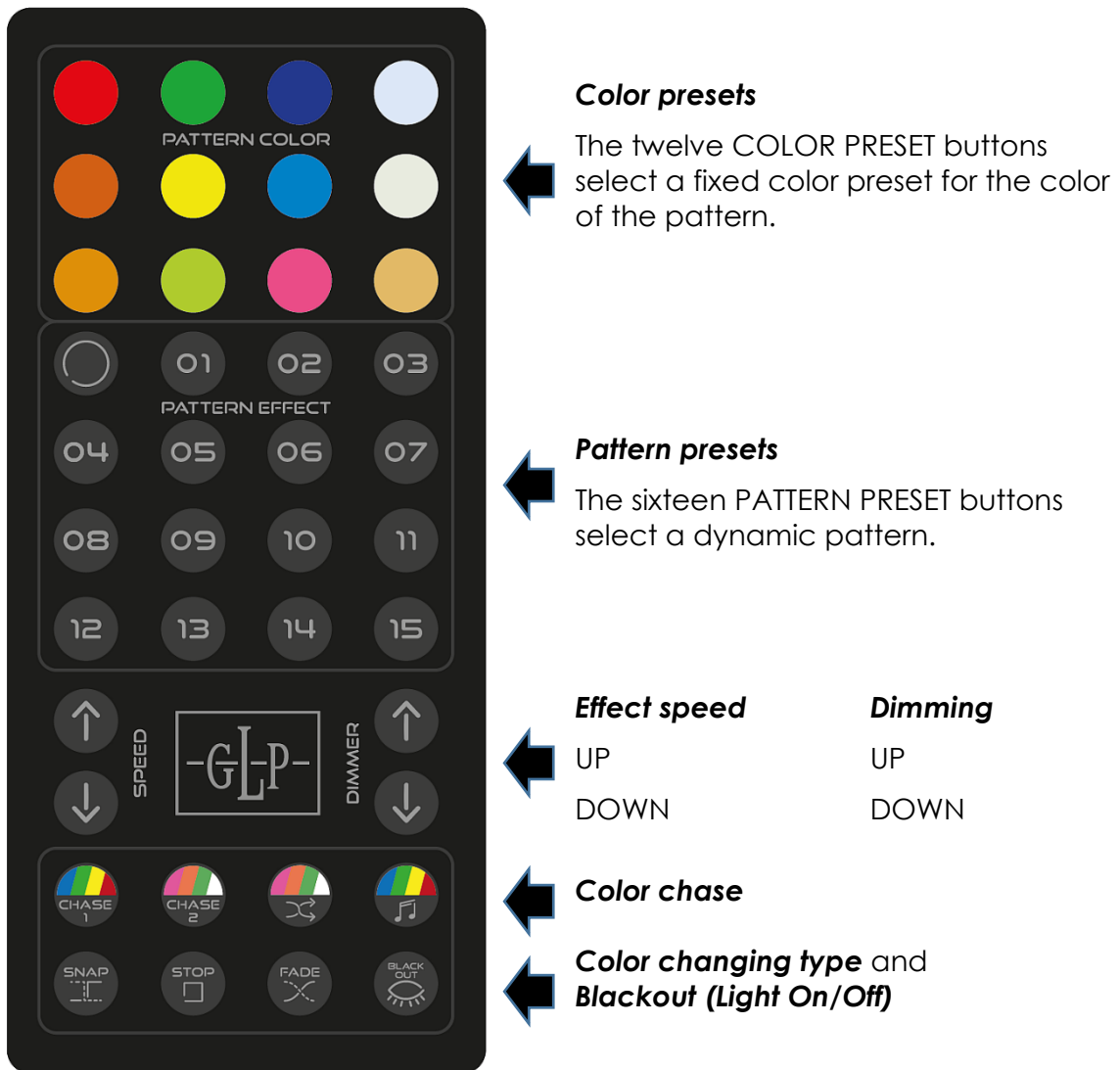

Figure 8. Remote control unit

Pattern color

The color presets available when using the remote control unit are as follows:

Red (CW01)	Green (CW02)	Blue (CW03)	White 8000K
Orange (CW08)	Yellow (CW06)	Light blue (CW11)	White 4200K
Amber (CW14)	Lime Green (CW20)	Pink (CW09)	White 2700K

Note that a wider range of color presets is available using the fixture's control panel.

Pattern Effects

When you select a pattern effect, the pattern will always start with a default color and run at medium speed. Once you have selected the pattern preset, you can change the speed and color of the pattern using the PATTERN COLOR and SPEED buttons. 16 pattern effects are available:

- Pattern 00 is the “open” pattern and will enable all 24 pixels. You can set the color by using the COLOR PRESET buttons.
- Patterns 02 to 07 are dynamic patterns over a black background. You can select the pattern color by using the COLOR PRESET buttons.
- Patterns 08 to 15 are dynamic patterns over a fixed color background. You can select the pattern color using the COLOR PRESET buttons. You cannot change the background color with the IR remote control unit (but you can change the background color using the MANUAL CONTROL menu in the CL1's integrated control panel).

Note that a wider range of effect patterns is available using the fixture's control panel.

Effect Speed

You can control the speed of a dynamic pattern using the SPEED UP and SPEED DOWN buttons. When you first select a pattern, it runs at medium speed until you adjust the speed using these buttons.

Global Intensity / Blackout

The DIMMER UP and DIMMER DOWN buttons control global light output intensity.

You can use the BLACKOUT button to temporarily toggle between light output and no output. The BLACKOUT button will only toggle output on and off: it will not change the selected dimmer value.

Note: You can control background and pattern intensity individually using the MANUAL CONTROL menu in the CL1's integrated control panel.

Automatic Colors

Four Color Chaser buttons are available:

- **Auto Rainbow Colors** – Automatic dynamic sequence of rainbow colors. You can adjust the color changing speed using the SPEED UP and SPEED DOWN buttons.
- **Auto Extended Colors** – Automatic dynamic sequence of a selection of colors from the DMX color wheel. You can adjust the color changing speed using the SPEED UP and SPEED DOWN buttons.
- **Auto Extended Colors Random** – This program is the same as “Auto Extended Colors” but colors are displayed in random order.
- **Music Trigger Rainbow Colors** – This program is the same as “Auto Rainbow Colors” but color changes are triggered by the CL1's internal microphone.

Color changing type

Three buttons let you set up and control color changing:

- The SNAP button creates a snap chase: each color in the sequence snaps instantly to the next color.
- The STOP button freezes automatic color changing at the current color.
- The FADE button creates a crossfading chase: each color in the sequence fades smoothly to the next color.

Light output On/Off

The BLACKOUT button toggles light output on and off.

9. Creative Light app control

If you select SIGNAL SOURCE → iQ.MESH in the SIGNAL SETTINGS menu (you can also press and hold the DOWN button to scroll through the control signal sources), you can control the CL1 using the GLP Creative Light smartphone app.

Using the Creative Light app, a smartphone can communicate with CL1 fixtures using GLP iQ.Mesh technology in which each fixture is capable of relaying data to other fixtures. The mesh system allows wireless control of networks over large distances.

You can find guidance about using the Creative Light app in the app itself once you have installed it, so this manual only gives you brief instructions to get you started.

Note that the Creative Light app is constantly being updated, and the appearance of the app may differ from the screenshot pictures given in this section. This user manual will be updated to match the app, so make sure that you have the latest version of this user manual.

Setting up the iQ.Mesh network

To control an installation containing CL1 fixtures with the Creative Light app, you must first link the fixtures to and configure the iQ.Mesh network. To do this:

1. Download the GLP Creative Light app from the App Store (iOS) or Play Store (Android). Pointing your smartphone at the correct QR code for your smartphone in Figure 9 will take you to the app:

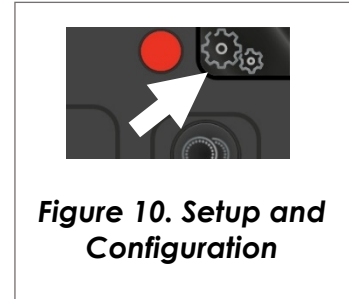

Figure 9. QR codes to obtain GLP Creative Light app

2. Switch on all the CL1 fixtures and open the control panel menus. Make sure that each fixture is unlinked from older iQ.Mesh Networks before linking. To unlink a CL1, either:
 - go to SIGNAL SETTINGS → iQ.MESH LINK/UNLINK and unlink the CL1, or
 - use a shortcut by pressing and holding the ENTER button for 6 seconds to load factory backup. This will return the CL1 to factory settings and delete any links to CRMX or iQ.Mesh.

3. Navigate to SIGNAL SETTINGS → SIGNAL SOURCE and select iQ.Mesh. You can also use a shortcut by pressing and holding the DOWN Button to change the control signal source. When the CL1 is set to SIGNAL SOURCE → iQ.Mesh, it will show a red rotating pixel to indicate that the fixture is not connected to an iQ.Mesh Network and is ready for linking.

4. Open the Creative Light app. See Figure 10. Tap on the *Setup and Configuration* button (arrowed) in the top right-hand corner of the main screen to open the Setup and Configuration screen.



5. See Figure 11. In the LINKING section at the bottom of the *Setup and Configuration* screen, tap on the *Discovered Unlinked Devices* button (arrowed). The app will search for unlinked devices. Each time it discovers a device it will add it to the list of discovered unlinked devices in the center of the screen.



6. You can now either add all the fixtures in the installation or add single fixtures to the network:

- To add all the fixtures, see Figure 12. Tap on the *Link all discovered devices* button.
- To add single fixtures, look down the list of discovered, unlinked devices in the center of the screen and tap on the CL1 that you want to add to the network. Then tap on the *Link Selected Fixture* button (see Figure 13) on the right of the screen.

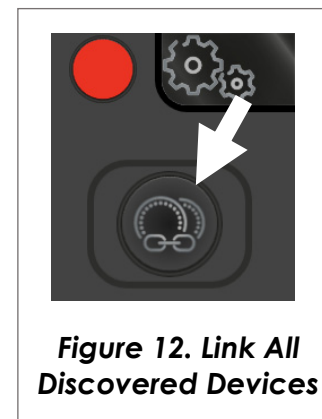

7. As soon as a CL1 fixture is linked to the iQ.Mesh network, it changes from showing a red rotating pixel to a green rotating pixel and the indicator light (top left in Figure 12) turns from red to green.

You can now control the CL1 using the Creative Light app.

Using the app is intuitive. You will also find tutorials in the app that will help you learn how to use the app's features.

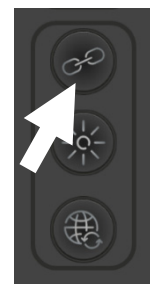

Using the Creative Light app

The GLP Creative Light app is arranged into three separate work areas:

Fixture Group Select area

Tapping on the *Fixture Group Select* button (see Figure 14) opens the *Fixture Group Select* area (see Figure 15).



Figure 14. Fixture Group Select button

This area lets you select which fixture groups should be controlled.

Buttons at the bottom of the screen let you:

- highlight a group in order to identify it in the installation,
- select all groups,
- de-select all groups (NONE), and
- clear all group programming.



Figure 15. Fixture Group Select area

Main / Live Area

The *Main / Live* area lets you control light output, select color and select dynamic effects.

The CL1 system lets you work in two layers:

- The first two pages (tap on the MASTER and MAIN buttons at the bottom of the screen) let you set the global intensity, select global intensity effects and choose a main color.
- The next four pages (tap on the PATTERN buttons at the bottom



Figure 16. Main / Live area

of the screen) give control of a second layer, the pattern layer, which will always appear on top of the main layer. As long the intensity of this layer is set to zero, the pattern layer is transparent and not visible. If you set pattern intensity to 100%, the layer is fully visible on top of the main layer. For the Pattern layer you can set intensity, intensity effects, colors and different pattern effects.

Playback Area

Tapping the *Playback* button (see Figure 17.) opens the *Playback* area, where you can save individual light settings from the *Main/Live* area.



Figure 17. Playbacks button

The *Playback* area lets you store or recall light scenes.

See Figure 18. The 24 *Playback* buttons on the left are permanent playback buttons. The 8 buttons on the right are temporary flash playback buttons.

To store a light scene from the *Main/Live* area, enable recording by pressing and holding the REC button (arrowed) for 3 seconds and then save the scene to one of the *Playback* buttons.



Figure 18. Playback area

You can also lock the *Playback* area by tapping and holding the lock button for 3 seconds. This will help you avoid deleting or storing playbacks by accident.

If you would like to learn more about the Creative Light app, please visit our homepage at www.glp.de.

10. DMX control (CL1+ only)

If you set the fixture to SIGNAL SOURCE → CRMX in the SIGNAL SETTINGS menu (you can also press and hold the DOWN button to scroll through the control signal sources), you can control the CL1+ using a DMX signal sent via a CRMX wireless DMX transmitter. The CL1+ has three DMX control modes, with the following possibilities.

Global intensity

The intensity channel provides dimming of the fixture in 8-bit resolution on channel 1 in all DMX modes.

Global Shutter / Pattern Shutter

You can apply a shutter / strobe effect to the whole fixture in all DMX modes. In Pattern DMX Mode, you can also apply the shutter / strobe effect to any pattern that you have superimposed onto the main 'scene'. The control options available for the whole fixture and for the pattern are the same:

- **Closed** blacks out the fixture.
- **Music Trigger Flash** gives one single flash each time you change the DMX value in this slot range. This option lets you manually send flashes whenever you like. This could be in time with a music beat, for example.
- **Random Pulse** is a shutter pulse that rhythmically increases and decreases output. You can adjust the rate of the pulse by changing the DMX value within this slot range.
- **Random Pulse Open** fades light in and then snaps to blackout. You can adjust the rate of the pulse by changing the DMX value within this slot range.
- **Random Pulse Close** fades light out and then snaps to full. You can adjust the rate of the pulse by changing the DMX value within this slot range.
- **Random Double Flash** performs a fast double flash. You can adjust the speed of the double flash by changing the DMX value within this slot range.
- **Strobe Random Pixel** sets individual pixels to flash at random, giving a kind of sparkle effect. You can adjust the rate of the sparkle by changing the DMX value within this slot range.
- **Strobe Random All** flashes all the fixture's pixels together with a random interval between flashes. This lets you set up a classic effect consisting of a random strobe running on multiple fixtures. You can adjust the speed of the random flashes by changing the DMX value within this slot range. Note that the random effect between multiple fixtures really is totally random!
- **Strobe Sync All** flashes all of the pixels of multiple fixtures in a perfectly synchronized strobe effect. You can adjust the speed of the strobe by changing the DMX value within this slot range.
- **Open** gives full intensity continuous output.

Virtual color wheel

The virtual color wheel channel gives quick access to fixed color presets. You can set the fixture to change from one color preset to another automatically with variable speed or in time with a music beat. You can decide whether the CL1 should snap from one color to the next or crossfade with variable fade time.

You can apply the color wheel effect to the whole fixture in Basic and Pattern DMX modes. In Pattern DMX Mode, you can also apply the color wheel effect to any pattern that you have superimposed onto the main 'scene'.

Note that the color wheel has higher priority than the RGB channels. The virtual color wheel channel must be set to DMX value 000 before you can use RGB color mixing.

The color wheel control options available for the whole fixture and for the pattern are the same:

- The first part of the color wheel channel (values 000 → 123) selects one of 30 color presets.
- The second part of the color wheel channel (values 128 → 191) gives automatic changing between color presets with a snap (instant) change. You can vary the color change rate from slow to fast, or you can link the instant color changes to the CL1's integrated audio trigger microphone. When using audio triggering you can decide whether a color change is triggered every beat or every 4, 8 or 16 beats.
- The third part of the color wheel channel (192 → 255) gives automatic changing between color presets with a smooth crossfade. You can vary the crossfading rate from slow to fast, or you can link the crossfading color changes to the CL1's integrated audio trigger microphone. When using audio triggering you can decide whether a color change is triggered every beat or every 4, 8 or 16 beats.

RGB / Pattern RGB

The RGB channels available in Basic and Pattern DMX Modes let you mix custom colors on all the fixture's pixels together (the main 'scene') and on any pattern that you select to run on top of the main 'scene'. Color mixing uses separate Red, Green and Blue intensity control.

The options for mixing custom colors on the whole fixture and on the superimposed pattern are identical.

Control / Settings

A special channel available in all DMX modes lets you modify some important fixture settings by DMX. Remotely adjust settings like this can be very helpful if fixture performance needs to be adjusted during the show or simply to create special scenes.

For most of these settings you need to send the required DMX value and then hold it for a certain number of seconds to activate.

Pattern Control (available in Pattern DMX Mode)

The different FX Pattern sequences available in Pattern DMX Mode can be superimposed onto the main 'scene' (the background). Each pattern consists of a sequence of steps and has active and inactive pixels. An active pixel shows the selected pattern color while an inactive pixel is fully transparent and will let the main 'scene' shine through.

Pattern effects are controlled with their own Pattern Master Intensity, Pattern Shutter, Pattern Color Wheel and Pattern RGB channels, which means that you can fade pattern effects in and out and apply intensity effects to patterns.

Pattern Intensity

The Pattern Intensity channel lets you set the intensity or visibility of the selected pattern. At 0% the pattern is invisible, and as you increase the DMX value on this channel the Pattern becomes more visible on top of the main 'scene' (the background). Patterns have priority over the main scene: if you increase the value on the Pattern Intensity channel from 0% to 100%, the pixels that are active in the pattern will crossfade from the main scene color to the pattern color.

Pattern Shutter

The Pattern Shutter channel offers the same effects as the Global Shutter channel (see '**Global Shutter / Pattern Shutter**' on page 28).

Pattern Select

The Pattern Select channel gives access to 40 dynamic pattern effects.

Pattern 00 (DMX value 000) is the basic pattern and simply sets all pixels to be active.

Patterns 01 to 40 are dynamic patterns. Each dynamic pattern consists of multiple static pattern steps. The number of steps can be different in different patterns.

Random Pattern change lets you automatically change pattern effects from slow (change pattern every 30 seconds) to fast (change pattern every second). You can also link pattern changes to the CL1's integrated audio triggering microphone. When using audio triggering you can decide whether a pattern change is triggered every beat or every 4, 8 or 16 beats.

Pattern Step/Speed

A pattern consists of a sequence of pattern steps. On the Pattern Step / Speed channel, you can:

- scroll to and select individual steps,
- take the change from one pattern step to the next and link it to the integrated audio triggering microphone with a 1:1 beat trigger, or
- set a pattern to run continuously with variable speed in different directions (clockwise or counterclockwise).

11. Mounting and installing



Warning! Follow the safety precautions given at the beginning of this manual when installing the CL1. Follow the safety regulations that are applicable in your region when installing the CL1 overhead. If the CL1 can cause injury or damage if it falls, secure it as described below with a secondary attachment such as a safety cable that is approved for the weight of the CL1.

You can install the CL1 in any orientation in a dry location.

Temporary installation

You can attach the CL1 to any magnetic surface by simply placing it on the surface. The magnet on the back of the CL1 is strong enough to hold the CL1 in position on a vertical surface. Non-slip rubber around the magnet helps to prevent the CL1 from sliding on the surface.

Secure the CL1 with a safety cable as described below if it can cause injury or damage if it falls.

Fixed installation

On surfaces or rigging trusses, use the integrated M6 threaded holes on the back of the CL1 for screws or bolts. All fasteners and attachments must be suitable for the purpose and environment.

GLP can supply optional installation and safety hardware for a wide range of applications. See 'Mounting on a UFO1 (Universal Fixing Object 1)' on page 32, for example.

Adding optical accessories

See Figure 19. Two front screens are supplied with the CL1: a clear screen for protection and a diffuser that softens the light.

To install a front screen, place its three magnetic mounts onto the magnetic mounting points on the front of the CL1 (see 'Product overview' on page 9). Screens are held in place magnetically.

To remove a front screen, simply lift it off the magnetic mounting points on the CL1.

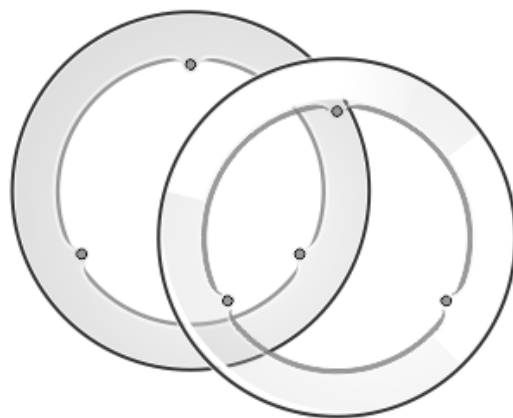

Figure 19. Front screens

Securing with a safety cable

Follow the safety regulations of your region when using the CL1 overhead. If the CL1 can cause injury or damage if it falls, secure it with a secondary attachment such as a safety cable that is approved for the weight of the CL1.

To secure the CL1:

1. See 'Product overview' on page 9. Fasten the included M6 Eyebolt into one of the three M6 threaded holes on the back of the CL1.
2. Attach a safety cable to the eyebolt and to a secure anchoring point so that it will hold the CL1 if it falls. Take up as much slack as possible in the safety cable.

Mounting on a UFO1 (Universal Fixing Object 1)

See Figure 20. The UFO1 (Universal Fixing Object 1) from GLP simplifies mounting and removing the CL1 from rigging trusses, microphone stands, camera tripods, flat surfaces, etc.

To mount the UFO1, you can:

- permanently fasten the UFO1 to a surface in any orientation using two screws **A** passed through the 4 mm holes in its center,
- fasten the UFO1 to a camera tripod or other photographic equipment stand, microphone stand etc. using the 1/4"-20 UNC and 3/8"-16 UNC threaded holes **B** provided on either side of the UFO1, or
- fasten a rigging clamp to the UFO1 by fastening a bolt into the M10 threaded hole **C** in the center of the UFO1. You can then fasten the rigging clamp to a rigging truss.

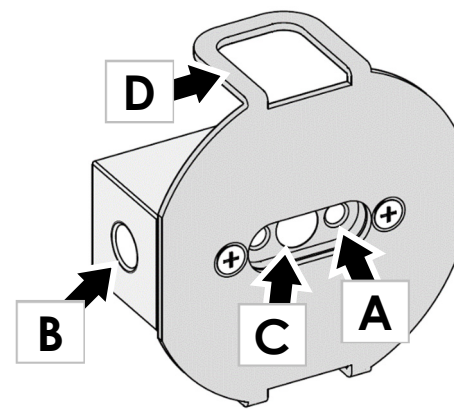

Figure 20. CL1 UFO

Once you have mounted the UFO1, you can then stick the CL1 to the UFO1 using the CL1's magnetic mount. You can then remove the CL1 for charging and replace instantly thanks to the magnetic mounting system.

The UFO1 provides eyelets **D** as anchoring points for safety cables. The eyelets can also be used to support USB cables to provide permanent power, for example.

Using an external power source

For continuous operation with no need to recharge the CL1's battery, it is possible to connect the CL1 to a power source via a USB cable connected to the CL1's USB-C input connector.

The power source must be capable of safely supplying a constant operating current of:

- 2 amps with the CL1 in **Normal** power mode, and
- 3 amps with the CL1 in **High** power mode.

12. Cleaning and product care



Warning! There are no user-serviceable parts inside the CL1. Do not attempt to open the CL1 or you may void the product warranty. Do not use water or any other liquid for cleaning.

Suggested cleaning intervals

The CL1 requires occasional cleaning to prevent the buildup of dust and dirt. The cleaning schedule depends on the operating environment.

Pay special attention to the LEDs, control panel display and IR remote control sensor (see 'Product overview' on page 9). Failure to keep the LEDs clean will significantly reduce light output and may cause damage. Regular cleaning will ensure maximum performance and reliable operation.

Use a soft, dry cloth only for cleaning. Do not use solvents or abrasive products of any kind. Apply only gentle pressure to the LEDs.

Checking firmware version

We recommend that you always have the latest firmware installed. Firmware, user documentation and other information about GLP products are available from the GLP website at www.glp.de.

You can check the CL1's firmware in the top right-hand corner of the CL1's integrated display. For details of the CL1's internal drivers, open the control menus and then scroll to and open the INFORMATION menu.

Uploading new firmware

The easiest way to upload new firmware to a CL1 is to use the Creative Light app to send the firmware over an iQ.Mesh Network.

It is also possible to upload new firmware using the optional DPROG firmware uploader hardware from GLP and a DMX-to-USB-C adapter. Contact your GLP supplier for more information.

Uploading with DProg

If you wish to upload firmware using GLP's DProg system, you will need the CL1 firmware package (software and change log file), a DMX to USB-C adapter cable and a D3-Prog uploader device from GLP.

To update the CL1's firmware using a D3-Prog device:

1. Upload the required firmware version to the D3-Prog device.
2. Connect the D3-Prog device to the CL1 using the DMX to USB-C adapter cable.
3. Switch on the CL1.
4. Select the CL1 firmware file in the D3-Prog device.

5. Start the upload process via DMX (Prog. via RS485/DMX). The CL1 display should show "UPDATE / Receiving Data" and a status bar. After a successful upload, FINISH appears in the display and the device switches off.

Uploading with iQ.Mesh

If you wish to upload firmware using the GLP Creative Light app, you will need a smartphone running the latest version of the app and the CL1 fixtures must be linked in a GLP iQ.Mesh network. The Creative Light app will always have the latest CL1 firmware if you keep the app updated via the Play Store (Android) or App Store (iOS).

Updating firmware involves two steps:

1. Check the iQ.Mesh firmware version and update if necessary.
2. Check the CL1 main firmware version and update if necessary.

Step 1 – Updating the iQ.Mesh firmware

To update the CL1's iQ.Mesh firmware over an iQ.Mesh network using the Creative Light app:

1. Switch on the CL1, open the control panel menus and set SIGNAL SOURCE → SIGNAL SETTINGS to iQ.MESH.
2. Open the Creative Light app. See Figure 21. Tap on the *Setup and Configuration* button in the top right-hand corner of the screen.
3. If the CL1 is discovered by the app, its name will appear in the *UNLINKED DEVICES* list. Next to the name of each CL1 you will see two different version numbers such as **1.2.0 / 4.0.2**. The first number is the CL1's currently installed main firmware version. The second number is the CL1's iQ.Mesh module firmware version. Keep both versions up to date.
4. If the CL1's iQ.Mesh firmware is out of date, its version number will be displayed in red. In this case, select the CL1 in the list and tap on the *Firmware Update* button (see Figure 22) on the right-hand side of the screen to carry out the iQ.Mesh firmware update.



Figure 21. Setup and Configuration

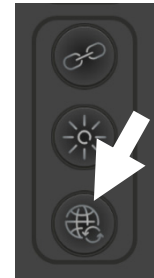

Figure 22. Firmware Update

Step 2 – Updating the CL1's main firmware

1. Keeping the CL1 selected in the *UNLINKED DEVICES* list, tap on the *Link Fixture* button (see Figure 23) on the right-hand side of the screen.
2. Once the CL1 is linked in the Creative Light app, switch to the *LINKED DEVICES* page and check that the CL1 now appears in the *LINKED DEVICES* list.
3. If the CL1's fixture firmware is out of date, its version number will be displayed in red. In this case, select the CL1 in the list and tap on the *Firmware Update* button (see Figure 22) on the right-hand side of the screen to carry out the update.

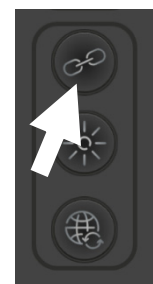

Figure 23. Link Fixture

Tip! Tapping and holding the Firmware Update button (see Figure 22) will update the firmware of all the fixtures in the list one by one.

Battery care

To get the best performance from the CL1's lithium-ion rechargeable battery:

- Recharge the battery immediately when it is discharged.
- Charge the battery fully before storing the product. Partially charged batteries lose capacity. Charge the battery every six months when the product is not in use.
- Apply the transport lock by holding MENU and ENTER pressed in together for 6 seconds before transporting the CL1.
- Apply the transport lock before putting the CL1 into storage.

Caring for the environment

Protect the environment:



- Send the product's packaging for recycling.
- Send the CL1 to an authorized recycling center at the end of its lifetime. Make sure that the battery is processed specifically as a lithium-ion battery.
- Do not dispose of the product or battery with household waste.

GLP Service and Support

Contact information for the nearest GLP Service and Support is available online at www.glp.de/en/service, by email at info@glp.de, or by telephone at the following numbers:

- GLP Germany: +49 (7248) 927 19-55
- GLP N. America: +1 818 767-8899
- GLP UK: +44 1392 690140
- GLP Asia: +852 (3151) 7730
- GLP Nordic: +46 737 57 11 40

13. Control menus

This chapter gives the contents of the menus in the control panel on the front of the CL1.

The menu items marked in yellow are available in the CL1+ only.

DMX Address		
1-512		Set fixture's DMX address
Control Mode		
M1 - RGB		All LED pixels controlled together. Controllable color and intensity plus shutter/intensity effects and a Control/Settings channel.
M2 - Pattern		Global intensity and shutter control. Color control of all LED pixels together in base layer. Top layer (Layer 2) with patterns can be superimposed onto base layer.
M3 - MultiPix		Global intensity and shutter control. Individual color control of each LED pixel.
Signal Settings		
Signal source	CRMX	Only CRMX signal is active, all other control signal sources are ignored
	iQ.Mesh	Only iQ.Mesh signal is active, all other control signal sources are ignored
	Manual / IR Remote	Fixture controlled by its own control buttons and display or by infrared remote if IR Remote is enabled (see below)
CRMX Link/Unlink	Unlinked / Linked	Shows current CRMX linking status. Press ENTER to unlink (confirm 3s)
iQ.Mesh Link/Unlink	Unlinked / Linked	Shows current iQ.Mesh linking status. Press ENTER to unlink (confirm 3s)
IR Remote control On/Off	On / Off	Fixture responds to / ignores signal from infrared remote
Fixture Settings		
No-signal behavior	Blackout	If no control signal present, fixture blacks out
	Hold last value	If no control signal present, fixture continues to use last valid control signal received
	Manual Control	If no control signal present, fixture goes into manual control mode
Mic sensitivity	01 ... 05 ... 10	Adjust sensitivity of audio triggering microphone, low (01) to high (10) sensitivity

Power Mode	High		Fixture performs at maximum brightness. Reduced operating time per battery charge. If battery is discharged, light switches off immediately.
	Normal		Fixture finds good balance between brightness and operating time per battery charge. If battery is discharged, light switches off immediately.
	Eco		Reduced brightness for longer operating time per battery charge. If battery is discharged, light switches off immediately.
Emergency Light	Enable / Disable	Enable	Enables shift to Emergency Light scene if external power is disconnected
		Disable	
	Scene Settings	Red	0 ... 100% intensity of RGB in Emergency Light scene
		Green	
Blue			
Capture DMX	Confirm	Captures current DMX values for RGB on channels 5 + 6 + 7 and uses them for Emergency Light scene	
Load Default Setting	Confirm 3 sec.		Returns individual fixture settings and manual control settings to default values (bold settings) so that all fixtures behave identically. NB: Signal configuration is not changed: this command does not affect DMX Address, Signal Source, Control Mode, etc. Connection to controller will not be lost.
Manual Control			
Master Intensity	0 ... 100%		Global output intensity
Main Color	Red	0 ... 100%	RGB intensity
	Green	0 ... 100%	
	Blue	0 ... 100%	
	Color Wheel	00 (open)...01..12	Background color preset selection. Has higher priority than RGB setting.
FX Layer	FX Intensity	000 ... 100%	Pattern visibility
	FX Pattern Select	00 (All) ... 01 ... 40	Pattern selection
	FX Speed	00 ... 10	Speed of selected pattern and color wheel. One direction only.
	FX Red	000 ... 100%	RGB adjustment of pattern color
	FX Green	000 ... 100%	
	FX Blue	000 ... 100%	
	FX Color Wheel	00 (open) ... 30 ... CW1 ... CW4	Pattern color preset selection. Has higher priority than RGB setting.
Color Crossfade	Snap		Adjust crossfading time between steps in pattern
	Fade		

Information		
Device Information	SW Version	<i>Fixture software (firmware) version</i>
	BL Version	<i>Bootloader version</i>
	HW Version	<i>Fixture hardware version</i>
	Lamp Hours	<i>Number of hours LEDs are powered on</i>
	Charging Cycles	<i>Number of battery charging cycles</i>
iQ.Mesh Information	iQ.Mesh Version	<i>iQ.Mesh firmware version</i>
	iQ.Mesh Status Info	<i>iQ.Mesh system status</i>
Service		
iQ.Mesh Upload		<i>Sets up the fixture to receive manual upload of iQ.Mesh module firmware.</i>
Load Setting Defaults	Confirm 3 sec.	<i>Returns individual fixture settings and manual control settings to default values (bold settings) so that all fixtures behave identically. Signal configuration is not changed: this command does not affect DMX Address, Signal Source, Control Mode, etc. Connection to controller will not be lost.</i>
Load Factory Backup	Confirm 3 sec.	<i>Returns individual fixture settings, manual control settings and all signal configuration settings to default values (bold settings) so that all fixtures behave identically. Important: this command affects DMX Address, Signal Source, Control Mode, etc. Connection to controller will be lost.</i>

14. DMX control modes overview (CL1+ only)

The following DMX control modes are available in the CL1+.

DMX Mode 1: Basic

DMX Mode 1: Basic uses 7 DMX channels.

Basic Mode provides dimming, shutter/strobe effects, a *Control/Settings* channel that lets you configure the fixture remotely via DMX, a virtual color wheel for fast access to color presets, and RGB color mixing. All of the fixture's pixels are controlled together.

Mode 1 Basic	
1	Global intensity
2	Global shutter / strobe
3	Control / Settings
4	Virtual color wheel (color presets)
5	Red
6	Green
7	Blue

DMX Mode 2: Pattern

DMX Mode 2: Pattern is the default DMX control mode. It uses 15 DMX channels.

Channels 1 – 7 in Pattern Mode are identical with Basic Mode. These channels provide dimming, shutter/strobe effects, a *Control/Settings* channel that lets you configure the fixture remotely via DMX, a virtual color wheel for fast access to color presets and RGB color mixing. These effects form the fixture's main 'scene'.

In addition to the above, Pattern Mode offers a powerful effects engine on channels 8 – 15 with 40 dynamic effect patterns that run on the fixture's 24 pixels. Patterns are superimposed onto the fixture's main scene. In other words, the main scene becomes a background for the pattern.

Mode 2 Pattern	
1	Global intensity
2	Global shutter / strobe
3	Control / Settings
4	Virtual color wheel (color presets)
5	Red
6	Green
7	Blue
8	Pattern visibility
9	Pattern shutter/strobe
10	Pattern select
11	Pattern step select / pattern speed
12	Pattern color wheel (color presets)
13	Pattern Red
14	Pattern Green
15	Pattern Blue

DMX Mode 3: MultiPix

DMX Mode 3: MultiPix uses 15 DMX channels.

Channels 1 – 3 in MultiPix Mode are identical with the other DMX modes. These channels provide dimming, shutter/strobe effects and a *Control/Settings* channel that lets you configure the fixture remotely via DMX.

In addition to these three channels, MultiPix Mode provides individual RGB control of each of the fixture's 24 pixels.

Pixels in the CL1 are numbered starting at the top and moving around the fixture in a clockwise direction:

- 12 o'clock = Pixel 1
- 3 o'clock = Pixel 6
- 6 o'clock = Pixel 12
- 9 o'clock = Pixel 18

Mode 3 MultiPix	
1	Global intensity
2	Global shutter / strobe
3	Control / Settings
4	Pixel 01 Red
5	Pixel 01 Green
6	Pixel 01 Blue
7	
...	RGB control of pixels 02 → 23 in sequence
72	
73	Pixel 24 Red
74	Pixel 24 Green
75	Pixel 24 Blue

15. DMX channel index (CL1+ only)

This section lists the commands available via DMX in the CL1+ fixture's three DMX modes.

DMX Mode 1: Basic

7 DMX Channels

Channel	Command	DMX range		Percent		Default DMX	Fade		
1	Global intensity	Global intensity 0→100%		0	255	0	100	0	Fade
2	Global shutter	Shutter closed		0	4	0	1.6	255	Snap
		Music trigger flash		5	9	2.0	3.5		Snap
		Random pulse slow → fast		10	39	3.9	15.3		Fade
		Random opening pulse slow → fast		40	69	15.7	27.1		Fade
		Random closing pulse slow → fast		70	99	27.5	38.8		Fade
		Random double flash slow → fast		100	129	39.2	50.6		Fade
		Random pixel strobe slow → fast		130	159	51.0	62.4		Fade
		Random all strobe slow → fast		160	199	62.7	78.0		Fade
		Strobe sync all pixels 1Hz → 10Hz		200	250	78.4	98.0		Fade
		Open		251	255	98.4	100		Snap
3	Control / Settings	<i>No function</i>		0	11	0	4.2	0	Snap
		No signal: Blackout (3s hold)		12	15	4.7	5.9		
		No signal: Hold (3s hold)		16	19	6.3	7.5		
		No signal: Manual Control (3s hold)		20	23	7.8	9.0		
		<i>No function</i>		24	39	9.4	15.3		
		Mic sensitivity: 10 (high, 1s hold)		40	43	15.7	16.9		
		Mic sensitivity: 09 (1s hold)		44	47	17.3	18.4		
		Mic sensitivity: 08 (1s hold)		48	51	18.8	20.0		
		Mic sensitivity: 07 (1s hold)		52	55	20.4	21.6		
		Mic sensitivity: 06 (1s hold)		56	59	22.0	23.1		
		Mic sensitivity: 05 (1s hold)		60	63	23.5	24.7		
		Mic sensitivity: 04 (1s hold)		64	67	25.1	26.3		
		Mic sensitivity: 03 (1s hold)		68	71	26.7	27.8		
		Mic sensitivity: 02 (1s hold)		72	75	28.2	29.4		
		Mic sensitivity: 01 (low, 1s hold)		76	91	29.8	35.7		
		Emergency light OFF (3s hold)		92	95	36.1	37.3		
		Emergency light ON (3s hold)		96	99	37.6	38.8		
		Emergency light Capture RGB values (3s hold)		100	103	39.2	40.4		
		<i>No function</i>		104	223	40.8	87.5		
		Power mode High (3s hold)		224	227	87.8	89.0		
		Power mode: Normal (3s hold)		228	231	89.4	90.6		
		Power mode: Eco (3s hold)		232	235	91.0	92.2		
		<i>No function</i>		236	239	92.5	93.7		
		Load default settings (5s hold)		240	243	94.1	95.3		
<i>No function</i>		244	255	95.7	100.0				

4	Color wheel	00 - Open	0	3	0.0	1.2	0	Snap
		01 - Red	4	7	1.6	2.7		
		02 - Green	8	11	3.1	4.3		
		03 - Blue	12	15	4.7	5.9		
		04 - Cyan	16	19	6.3	7.5		
		05 - Magenta	20	23	7.8	9.0		
		06 - Yellow	24	27	9.4	10.6		
		07 - Orange	28	31	11.0	12.2		
		08 - Deep Orange	32	35	12.5	13.7		
		09 - Pink	36	39	14.1	15.3		
		10 - Deep Purple	40	43	15.7	16.9		
		11 - Light Blue	44	47	17.3	18.4		
		12 - Deep Amber	48	51	18.8	20.0		
		13 - Light Amber	52	55	20.4	21.6		
		14 - Deep Golden Amber	56	59	22.0	23.1		
		15 - Straw	60	63	23.5	24.7		
		16 - Sunset red	64	67	25.1	26.3		
		17 - Light Pink	68	71	26.7	27.8		
		18 - Light Lavender	72	75	28.2	29.4		
		19 - Lavender	76	79	29.8	31.0		
		20 - Lime Green	80	83	31.4	32.5		
		21 - Apricot	84	87	32.9	34.1		
		22 - Pale Salmon	88	91	34.5	35.7		
		23 - Dark Salmon	92	95	36.1	37.3		
		24 - Light Salmon	96	99	37.6	38.8		
		25 - White 10.000K	100	103	39.2	40.4		
		26 - White 8.000K	104	107	40.8	42.0		
		27 - White 6.000K	108	111	42.4	43.5		
		28 - White 4.200K	112	115	43.9	45.1		
		29 - White 3.200K	116	119	45.5	46.7		
		30 - White 2.700K	120	123	47.1	48.2		
		No function	124	125	48.6	49.0		
		Color wheel snap stop	126	129	49.4	50.6		
Color wheel snap slow ... fast	130	175	51.0	68.6				
Color wheel snap music trigger (1:1 / every trigger)	176	179	69.0	70.2				
Color wheel snap music trigger (1:4 / every 4th trigger)	180	183	70.6	71.8				
Color wheel snap music trigger (1:8 / every 8th trigger)	184	187	72.2	73.3				
Color wheel snap music trigger (1:16 / every 16th trigger)	188	191	73.7	74.9				
Color wheel fade stop	192	195	75.3	76.5				
Color wheel fade slow ... fast	196	239	76.9	93.7				
Color wheel fade music trigger (1:1 / every trigger)	240	243	94.1	95.3				
Color wheel fade music trigger (1:4 / every 4th trigger)	244	247	95.7	96.9				
Color wheel fade music trigger (1:8 / every 8th trigger)	248	251	97.3	98.4				
Color wheel fade music trigger (1:16 / every 16th trigger)	252	255	98.8	100.0				
5	Red	Red intensity 0→100%	0	255	0	100	0	Fade
6	Green	Green intensity 0→100%	0	255	0	100	0	Fade
7	Blue	Blue intensity 0→100%	0	255	0	100	0	Fade

DMX Mode 2: Pattern (default mode)

15 DMX Channels

Channel	Command	DMX range		Percent		Default DMX	Fade	
1	Global intensity	Global intensity 0→100%	0	255	0	100	0	Fade
2	Global shutter	Shutter closed	0	4	0	1.6	255	Snap
		Music trigger flash	5	9	2.0	3.5		Snap
		Random pulse slow → fast	10	39	3.9	15.3		Fade
		Random opening pulse slow → fast	40	69	15.7	27.1		Fade
		Random closing pulse slow → fast	70	99	27.5	38.8		Fade
		Random double flash slow → fast	100	129	39.2	50.6		Fade
		Random pixel strobe slow → fast	130	159	51.0	62.4		Fade
		Random all strobe slow → fast	160	199	62.7	78.0		Fade
		Strobe sync all pixels 1Hz → 10Hz	200	250	78.4	98.0		Fade
		Open	251	255	98.4	100		Snap
3	Control / Settings	<i>No function</i>	0	11	0	4.2	0	Snap
		No signal: Blackout (3s hold)	12	15	4.7	5.9		
		No signal: Hold (3s hold)	16	19	6.3	7.5		
		No signal: Manual Control (3s hold)	20	23	7.8	9.0		
		<i>No function</i>	24	39	9.4	15.3		
		Mic sensitivity: 10 (high, 1s hold)	40	43	15.7	16.9		
		Mic sensitivity: 09 (1s hold)	44	47	17.3	18.4		
		Mic sensitivity: 08 (1s hold)	48	51	18.8	20.0		
		Mic sensitivity: 07 (1s hold)	52	55	20.4	21.6		
		Mic sensitivity: 06 (1s hold)	56	59	22.0	23.1		
		Mic sensitivity: 05 (1s hold)	60	63	23.5	24.7		
		Mic sensitivity: 04 (1s hold)	64	67	25.1	26.3		
		Mic sensitivity: 03 (1s hold)	68	71	26.7	27.8		
		Mic sensitivity: 02 (1s hold)	72	75	28.2	29.4		
		Mic sensitivity: 01 (low, 1s hold)	76	91	29.8	35.7		
		Emergency light OFF (3s hold)	92	95	36.1	37.3		
		Emergency light ON (3s hold)	96	99	37.6	38.8		
		Emergency light Capture RGB values (3s hold)	100	103	39.2	40.4		
		<i>No function</i>	104	223	40.8	87.5		
		Power mode High (3s hold)	224	227	87.8	89.0		
		Power mode: Normal (3s hold)	228	231	89.4	90.6		
		Power mode: Eco (3s hold)	232	235	91.0	92.2		
		<i>No function</i>	236	239	92.5	93.7		
Load default settings (5s hold)	240	243	94.1	95.3				
<i>No function</i>	244	255	95.7	100.0				

4	Color wheel	00 - Open	0	3	0.0	1.2	0	Snap
		01 - Red	4	7	1.6	2.7		
		02 - Green	8	11	3.1	4.3		
		03 - Blue	12	15	4.7	5.9		
		04 - Cyan	16	19	6.3	7.5		
		05 - Magenta	20	23	7.8	9.0		
		06 - Yellow	24	27	9.4	10.6		
		07 - Orange	28	31	11.0	12.2		
		08 - Deep Orange	32	35	12.5	13.7		
		09 - Pink	36	39	14.1	15.3		
		10 - Deep Purple	40	43	15.7	16.9		
		11 - Light Blue	44	47	17.3	18.4		
		12 - Deep Amber	48	51	18.8	20.0		
		13 - Light Amber	52	55	20.4	21.6		
		14 - Deep Golden Amber	56	59	22.0	23.1		
		15 - Straw	60	63	23.5	24.7		
		16 - Sunset red	64	67	25.1	26.3		
		17 - Light Pink	68	71	26.7	27.8		
		18 - Light Lavender	72	75	28.2	29.4		
		19 - Lavender	76	79	29.8	31.0		
		20 - Lime Green	80	83	31.4	32.5		
		21 - Apricot	84	87	32.9	34.1		
		22 - Pale Salmon	88	91	34.5	35.7		
		23 - Dark Salmon	92	95	36.1	37.3		
		24 - Light Salmon	96	99	37.6	38.8		
		25 - White 10.000K	100	103	39.2	40.4		
		26 - White 8.000K	104	107	40.8	42.0		
		27 - White 6.000K	108	111	42.4	43.5		
		28 - White 4.200K	112	115	43.9	45.1		
		29 - White 3.200K	116	119	45.5	46.7		
		30 - White 2.700K	120	123	47.1	48.2		
		No function	124	125	48.6	49.0		
		Color wheel rotation snap stop	126	129	49.4	50.6		
		Color wheel rotation snap slow → fast	130	175	51.0	68.6		
Color wheel rotation snap music trigger (1:1 / every trigger)	176	179	69.0	70.2				
Color wheel rotation snap music trigger (1:4 / every 4th trigger)	180	183	70.6	71.8				
Color wheel rotation snap music trigger (1:8 / every 8th trigger)	184	187	72.2	73.3				
Color wheel rotation snap music trigger (1:16 / every 16th trigger)	188	191	73.7	74.9				
Color wheel rotation fade stop	192	195	75.3	76.5				
Color wheel rotation fade slow → fast	196	239	76.9	93.7				
Color wheel rotation fade music trigger (1:1 / every trigger)	240	243	94.1	95.3				
Color wheel rotation fade music trigger (1:4 / every 4th trigger)	244	247	95.7	96.9				
Color wheel rotation fade music trigger (1:8 / every 8th trigger)	248	251	97.3	98.4				
Color wheel rotation fade music trigger (1:16 / every 16th trigger)	252	255	98.8	100.0				
5	Red	Red intensity 0→100%	0	255	0	100	0	Fade
6	Green	Green intensity 0→100%	0	255	0	100	0	Fade
7	Blue	Blue intensity 0→100%	0	255	0	100	0	Fade

8	Pattern master	Pattern visibility	0	255	0	100	0	Fade
9	Pattern shutter	Shutter closed	0	4	0	1.6	255	Snap
		Music trigger flash	5	9	2.0	3.5		Snap
		Random pulse slow → fast	10	39	3.9	15.3		Fade
		Random opening pulse slow → fast	40	69	15.7	27.1		Fade
		Random closing pulse slow → fast	70	99	27.5	38.8		Fade
		Random double flash slow → fast	100	129	39.2	50.6		Fade
		Random pixel strobe slow → fast	130	159	51.0	62.4		Fade
		Random all strobe slow → fast	160	199	62.7	78.0		Fade
		Strobe sync all pixels 1Hz → 10Hz	200	250	78.4	98.0		Fade
		Open	251	255	98.4	100		Snap
10	Pattern selection	Pattern 000 (No Pattern)	0	10	0.0	3.9	Snap	0
		Pattern 001	11	15	4.3	5.9		
		Pattern 002	16	20	6.3	7.8		
		Pattern 003	21	25	8.2	9.8		
		Pattern 004	26	30	10.2	11.8		
		Pattern 005	31	35	12.2	13.7		
		Pattern 006	36	40	14.1	15.7		
		Pattern 007	41	45	16.1	17.6		
		Pattern 008	46	50	18.0	19.6		
		Pattern 009	51	55	20.0	21.6		
		Pattern 010	56	60	22.0	23.5		
		Pattern 011	61	65	23.9	25.5		
		Pattern 012	66	70	25.9	27.5		
		Pattern 013	71	75	27.8	29.4		
		Pattern 014	76	80	29.8	31.4		
		Pattern 015	81	85	31.8	33.3		
		Pattern 016	86	90	33.7	35.3		
		Pattern 017	91	95	35.7	37.3		
		Pattern 018	96	100	37.6	39.2		
		Pattern 019	101	105	39.6	41.2		
		Pattern 020	106	110	41.6	43.1		
		Pattern 021	111	115	43.5	45.1		
		Pattern 022	116	120	45.5	47.1		
		Pattern 023	121	125	47.5	49.0		
		Pattern 024	126	130	49.4	51.0		
		Pattern 025	131	135	51.4	52.9		
		Pattern 026	136	140	53.3	54.9		
		Pattern 027	141	145	55.3	56.9		
		Pattern 028	146	150	57.3	58.8		
		Pattern 029	151	155	59.2	60.8		
		Pattern 030	156	160	61.2	62.7		
		Pattern 031	161	165	63.1	64.7		
		Pattern 032	166	170	65.1	66.7		
		Pattern 033	171	175	67.1	68.6		
		Pattern 034	176	180	69.0	70.6		
		Pattern 035	181	185	71.0	72.5		
		Pattern 036	186	190	72.9	74.5		
		Pattern 037	191	195	74.9	76.5		
		Pattern 038	196	200	76.9	78.4		
		Pattern 039	201	205	78.8	80.4		
		Pattern 040	206	210	80.8	82.4		

10	Pattern selection (contd.)	Random pattern auto change stop	211	212	82.7	83.1	Snap	0
		Random pattern auto change slow → fast	213	247	83.5	96.9	Fade	
		Random pattern music trigger change (1:8 / every 8th beat)	248	249	97.3	97.6	Snap	
		Random pattern music trigger change (1:16 / every 16th beat)	250	251	98.0	98.4		
		Random pattern music trigger change (1:32 / every 32nd beat)	252	253	98.8	99.2		
		Random pattern music trigger change (1:64 / every 64th beat)	254	255	99.6	100.0		
11	Pattern step/speed	Pattern step 01	0	1	0.0	0.4	Snap	0
		Pattern step 02	2	3	0.8	1.2		
		Pattern step 03	4	5	1.6	2.0		
		Pattern step 04	6	7	2.4	2.7		
		Pattern step 05	8	9	3.1	3.5		
		Pattern step 06	10	11	3.9	4.3		
		Pattern step 07	12	13	4.7	5.1		
		Pattern step 08	14	15	5.5	5.9		
		Pattern step 09	16	17	6.3	6.7		
		Pattern step 10	18	19	7.1	7.5		
		Pattern step 11	20	21	7.8	8.2		
		Pattern step 12	22	23	8.6	9.0		
		Pattern step 13	24	25	9.4	9.8		
		Pattern step 14	26	27	10.2	10.6		
		Pattern step 15	28	29	11.0	11.4		
		Pattern step 16	30	31	11.8	12.2		
		Pattern step 17	32	33	12.5	12.9		
		Pattern step 18	34	35	13.3	13.7		
		Pattern step 19	36	37	14.1	14.5		
		Pattern step 20	38	39	14.9	15.3		
		Pattern step 21	40	41	15.7	16.1		
		Pattern step 22	42	43	16.5	16.9		
		Pattern step 23	44	45	17.3	17.6		
		Pattern step 24	46	47	18.0	18.4		
		Pattern step 25	48	49	18.8	19.2		
		Pattern step 26	50	51	19.6	20.0		
		Pattern step 27	52	53	20.4	20.8		
		Pattern step 28	54	55	21.2	21.6		
		Pattern step 29	56	57	22.0	22.4		
		Pattern step 30	58	59	22.7	23.1		
		Pattern step 31	60	61	23.5	23.9		
		Pattern step 32	62	63	24.3	24.7		
		Pattern step 33	64	65	25.1	25.5		
		Pattern step 34	66	67	25.9	26.3		
		Pattern step 35	68	69	26.7	27.1		
		Pattern step 36	70	71	27.5	27.8		
		Pattern step 37	72	73	28.2	28.6		
		Pattern step 38	74	75	29.0	29.4		
		Pattern step 39	76	77	29.8	30.2		
		Pattern step 40	78	79	30.6	31.0		

11	Pattern step/speed (contd.)	Pattern step 41	80	81	31.4	31.8	Snap	0
		Pattern step 42	82	83	32.2	32.5		
		Pattern step 43	84	85	32.9	33.3		
		Pattern step 44	86	87	33.7	34.1		
		Pattern step 45	88	89	34.5	34.9		
		Pattern step 46	90	91	35.3	35.7		
		Pattern step 47	92	93	36.1	36.5		
		Pattern step 48	94	95	36.9	37.3		
		No function	96	124	37.6	48.6		
		Pattern step music trigger (1:1 / step changes every trigger)	125	127	49.0	49.8		
		CW pattern movement fast → slow	128	190	50.2	74.5		
		Pattern movement stop	191	192	74.9	75.3		
		CCW pattern movement slow → fast	193	255	75.7	100.0		
		12	Pattern color wheel	00 - Open	0	3	0.0	1.2
01 - Red	4			7	1.6	2.7		
02 - Green	8			11	3.1	4.3		
03 - Blue	12			15	4.7	5.9		
04 - Cyan	16			19	6.3	7.5		
05 - Magenta	20			23	7.8	9.0		
06 - Yellow	24			27	9.4	10.6		
07 - Orange	28			31	11.0	12.2		
08 - Deep Orange	32			35	12.5	13.7		
09 - Pink	36			39	14.1	15.3		
10 - Deep Purple	40			43	15.7	16.9		
11 - Light Blue	44			47	17.3	18.4		
12 - Deep Amber	48			51	18.8	20.0		
13 - Light Amber	52			55	20.4	21.6		
14 - Deep Golden Amber	56			59	22.0	23.1		
15 - Straw	60			63	23.5	24.7		
16 - Sunset red	64			67	25.1	26.3		
17 - Light Pink	68			71	26.7	27.8		
18 - Light Lavender	72			75	28.2	29.4		
19 - Lavender	76			79	29.8	31.0		
20 - Lime Green	80			83	31.4	32.5		
21 - Apricot	84			87	32.9	34.1		
22 - Pale Salmon	88			91	34.5	35.7		
23 - Dark Salmon	92			95	36.1	37.3		
24 - Light Salmon	96			99	37.6	38.8		
25 - White 10 000 K	100			103	39.2	40.4		
26 - White 8000 K	104			107	40.8	42.0		
27 - White 6000 K	108			111	42.4	43.5		
28 - White 4200 K	112			115	43.9	45.1		
29 - White 3200 K	116			119	45.5	46.7		
30 - White 2700 K	120			123	47.1	48.2		
No function	124			125	48.6	49.0		
Color wheel rotation snap stop	126			129	49.4	50.6		
Color wheel rotation snap slow → fast	130	175	51.0	68.6	Fade			

12	Pattern color wheel (contd.)	Color wheel snap music trigger (1:1 / every trigger)	176	179	69.0	70.2		Snap
		Color wheel snap music trigger (1:4 / every 4th trigger)	180	183	70.6	71.8		
		Color wheel snap music trigger (1:8 / every 8th trigger)	184	187	72.2	73.3		
		Color wheel snap music trigger (1:16 / every 16th trigger)	188	191	73.7	74.9		
		Color wheel fade stop	192	195	75.3	76.5		Fade
		Color wheel fade slow → fast	196	239	76.9	93.7		
		Color wheel fade music trigger (1:1 / every trigger)	240	243	94.1	95.3		Snap
		Color wheel fade music trigger (1:4 / every 4th trigger)	244	247	95.7	96.9		
		Color wheel fade music trigger (1:8 / every 8th trigger)	248	251	97.3	98.4		
		Color wheel fade music trigger (1:16 / every 16th trigger)	252	255	98.8	100.0		
13	Pattern Red	Red intensity 0→100%	0	255	0	100	0	Fade
14	Pattern Green	Green intensity 0→100%	0	255	0	100	0	Fade
15	Pattern Blue	Blue intensity 0→100%	0	255	0	100	0	Fade

DMX Mode 3: MultiPix

75 DMX Channels

Channel	Command	DMX range	Percent	Default DMX	Fade	
1	Global intensity Global intensity 0→100%	0 255	0 100	0	Fade	
2	Global shutter	Shutter closed	0 4	0 1.6	255	Snap
		Music trigger flash	5 9	2.0 3.5		Snap
		Random pulse slow → fast	10 39	3.9 15.3		Fade
		Random opening pulse slow → fast	40 69	15.7 27.1		Fade
		Random closing pulse slow → fast	70 99	27.5 38.8		Fade
		Random double flash slow → fast	100 129	39.2 50.6		Fade
		Random pixel strobe slow → fast	130 159	51.0 62.4		Fade
		Random all strobe slow → fast	160 199	62.7 78.0		Fade
		Strobe sync all pixels 1Hz → 10Hz	200 250	78.4 98.0		Fade
		Open	251 255	98.4 100		Snap
3	Control / Settings	No function	0 11	0 4.2	0	Snap
		No signal: Blackout (3s hold)	12 15	4.7 5.9		
		No signal: Hold (3s hold)	16 19	6.3 7.5		
		No signal: Manual Control (3s hold)	20 23	7.8 9.0		
		No function	24 39	9.4 15.3		
		Mic sensitivity: 10 (high, 1s hold)	40 43	15.7 16.9		
		Mic sensitivity: 09 (1s hold)	44 47	17.3 18.4		
		Mic sensitivity: 08 (1s hold)	48 51	18.8 20.0		
		Mic sensitivity: 07 (1s hold)	52 55	20.4 21.6		
		Mic sensitivity: 06 (1s hold)	56 59	22.0 23.1		
		Mic sensitivity: 05 (1s hold)	60 63	23.5 24.7		
		Mic sensitivity: 04 (1s hold)	64 67	25.1 26.3		
		Mic sensitivity: 03 (1s hold)	68 71	26.7 27.8		
		Mic sensitivity: 02 (1s hold)	72 75	28.2 29.4		
		Mic sensitivity: 01 (low, 1s hold)	76 91	29.8 35.7		
		Emergency light OFF (3s hold)	92 95	36.1 37.3		
		Emergency light ON (3s hold)	96 99	37.6 38.8		
		Emergency light Capture RGB values (3s hold)	100 103	39.2 40.4		
		No function	104 223	40.8 87.5		
		Power mode High (3s hold)	224 227	87.8 89.0		
Power mode: Normal (3s hold)	228 231	89.4 90.6				
Power mode: Eco (3s hold)	232 235	91.0 92.2				
No function	236 239	92.5 93.7				
Load default settings (5s hold)	240 243	94.1 95.3				
No function	244 255	95.7 100.0				
4	Pixel 01 Red Red intensity 0→100%	0 255	0 100	0	Fade	
5	Pixel 01 Green Green intensity 0→100%	0 255	0 100	0	Fade	
6	Pixel 01 Blue Blue intensity 0→100%	0 255	0 100	0	Fade	
... Pixels 02 ... 23						
73	Pixel 24 Red Red intensity 0→100%	0 255	0 100	0	Fade	
74	Pixel 24 Green Green intensity 0→100%	0 255	0 100	0	Fade	
75	Pixel 24 Blue Blue intensity 0→100%	0 255	0 100	0	Fade	

16. Technical Data

Optical

- Light source: 24 x 300 mW RGB LEDs
- LED Lifetime: 50 000 hours (to >70% light output)

Control

CL1 and CL1+

- Integrated control panel with monochrome OLED display
- Infrared remote control
- GLP Creative Light smartphone app and iQ.Mesh network
- Audio triggering with integrated Sound2Light microphone

CL1+ only

- DMX channels: 7, 15 or 75
- DMX control modes: 3
- Control protocols: Standard DMX (USITT DMX512-A), LumenRadio CRMX TiMo

Electrical

- Power Modes: High, Normal, Eco
- Power input: 5 VDC
- Maximum current draw: 2 A @ 5 VDC
- Battery type: Lithium-ion 10 000 mAh

Thermal

- Operating temperature range: 0° C (32° F) to 45° C (115° F)
- Charging temperature range: 15° C (59° F) to 35° C (95° F)
- Cooling: Convection
- Overtemperature protection: Automatic thermal cutout
- Maximum dissipated heat: 25 BTU/hr.

Installation

- Orientation: Any
- Location: Dry location only
- Min. distance to combustible materials: 20 cm (8 ins.)
- Min. distance to illuminated surfaces: 30 cm (1 ft.)

Construction

- High-impact flame-resistant thermoplastic, aluminum, steel
- Ingress protection: IP20
- Kensington system security lock

Connections

- Charging: USB-C connector, two charging ports
- Firmware update: USB-C or GLP iQ.Mesh network

Included items

- 1 x GLP CL1 or CL1+ fixture
- 1 x GLP CL1 Front Screen, white
- 1 x GLP CL1 Front Screen, clear
- 1 x GLP Creative Light IR Remote Control Unit
- 1 x GLP CL1 / CL1+ Quick Start Guide
- 1 x USB-A to USB-C Charging Cable, 1 m
- 1 x M6 Eyelet Screw for secondary attachment

Dimensions and weight (identical for CL1 and CL1+)

- Diameter: 157 mm (6.2 in)
- Depth: 32 mm (1.3 in)
- Weight including front-mounted optical accessory: 570 g (20.2 oz.)
- Weight, front-mounted optical accessory alone: 35 g (1.3 oz.)

GLP Creative Light smartphone app minimum requirements

Bluetooth version: 4.2 or newer

Android version: 5.1 Lollipop or newer

iOS Version: iOS 8 or newer

Screen resolution: 480 x 850 pixels

RAM: 1 GB

Free storage space: Android 50 MB minimum, iOS 80 MB

17. Dimensions

Creative Light 1 (CL1)
Creative Light 1 Plus (CL1+)

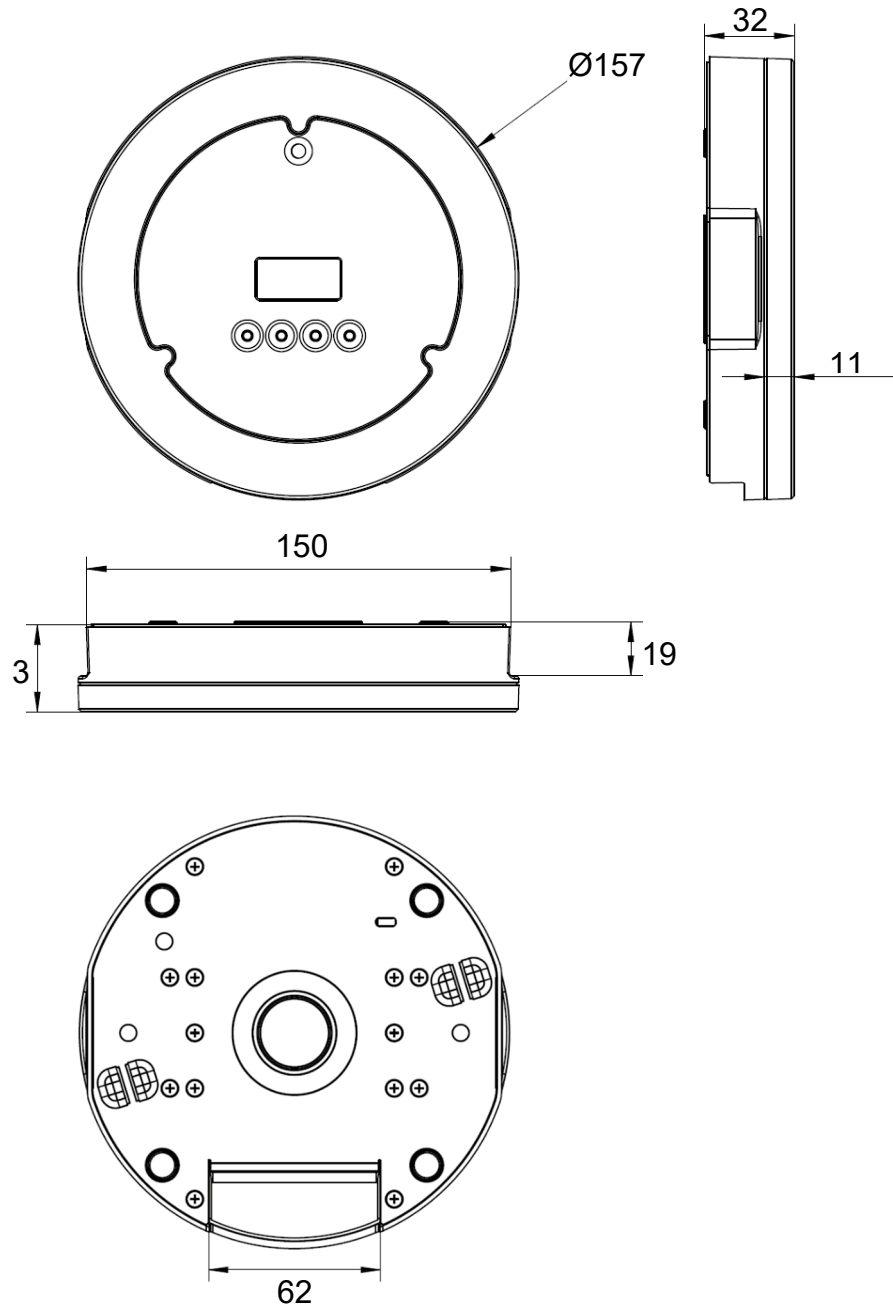

Dimensions are given in millimeters

CL1 UFO1 (Universal Fixing Object 1)

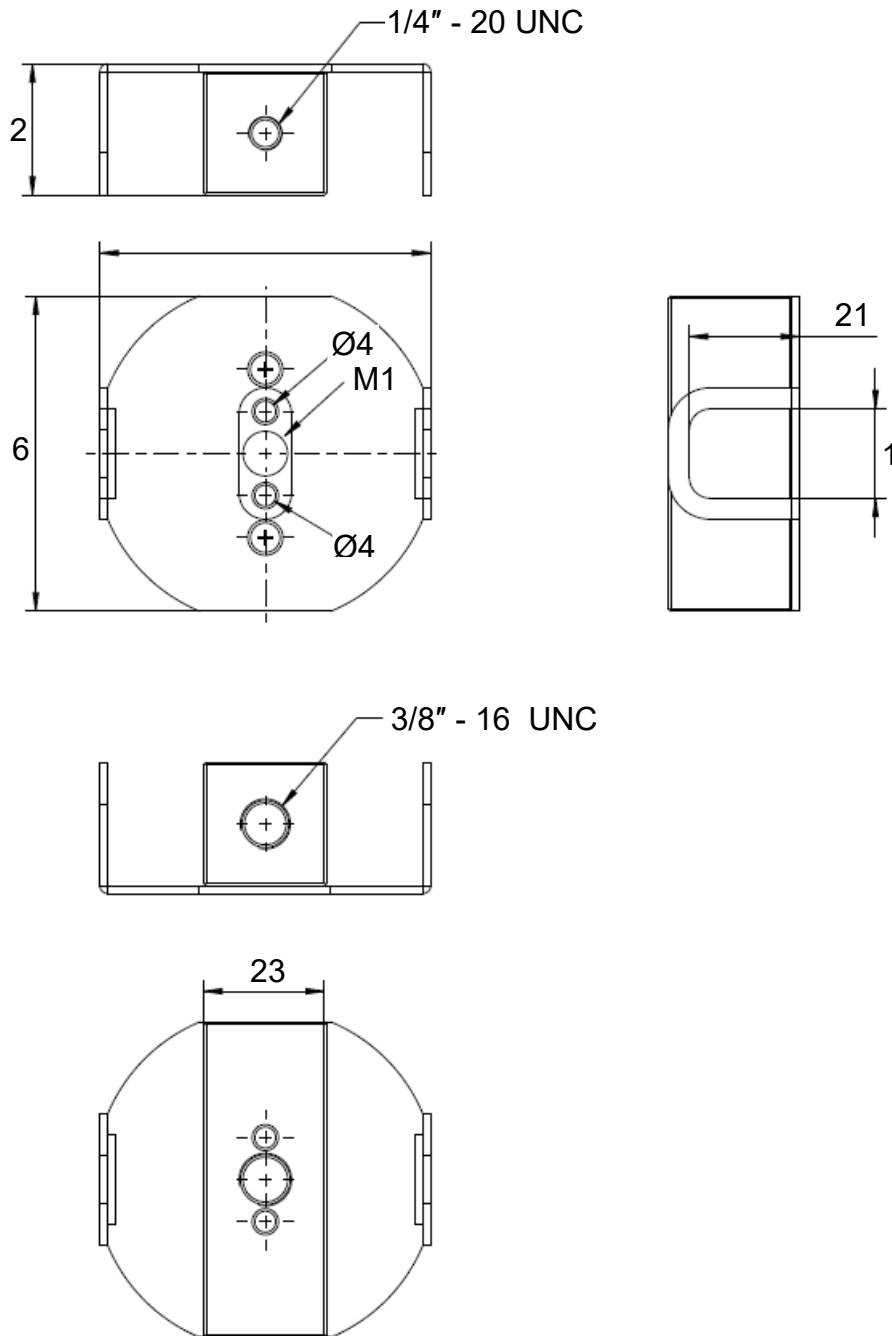

Dimensions are given in millimeters

-GLP-